

# Specification for

## Model : DSFP

Original Release Date : July 03, 2012

# OPHIT

## Revision History

Version Number	Revision Date	Author	Description of Changes
1.0	July 03, 2012	K.H. Kim	Initial Version

## **TABLE OF CONTENTS**

### **1. General Description**

### **2. General Specification**

### **3. Absolute Maximum Ratings**

### **4. Electrical Specification**

#### 4.1 Electrical Specification

##### 4.1.1 Transmitter Module

##### 4.1.2 Receiver Module

#### 4.2 Connector Pin Assignment

##### 4.2.1 Transmitter

##### 4.2.2 Receiver

### **5. Mechanical Specification**

#### 5.1 Case Dimension

##### 5.1.1 Transmitter & Receiver

#### 5.2 Cable

### **6. RoHS**

## 1. General Description

**DSFP**, This unique fiber optical transceiver let your PC, digital HDTV or Projector extend up to 1,000 meter(3300ft) away from host based on DisplayPort standard without signal degradation by WQXGA (2560X1600) resolution.

- High Speed and long distance transmission by optical system
- Compatible with DisplayPort standard V1.1a
- Main-link video signal / AUX data and Hot Plug Detection signal is transmitted by-  
1 channel multimode optical fiber
- External power supply use
- DPCD(DisplayPort Configuration Data) compliant  
(Does not support HDCP mode)

## 2. General Specification

Parameter	Symbol	
	Transmitter	Receiver
Optical Converter	850nm, 4Ch Transmit OSA 911nm, 1Ch VCSEL 980nm, 1Ch PIN P/D Diode	850nm, 4Ch Receive OSA 980nm, 1Ch VCSEL 911nm, 1Ch PIN P/D Diode
Input and Output Signal	ANSI8B/10B (DisplayPort 1.1a standard)	
Video Bandwidth	3.5Gbps / Channel	
Module Dimension	33 x 12 x 282 mm (W x H x D)	
Module Weight	--	--
Using electrical Connector	20 pin DisplayPort Plug(input)	20 pin DisplayPort Plug (Output)
Optical Connector	1 SC Connector	1 SC Connector
Recommended Fiber	50/125um Multi-mode glass-fiber	
Maximum Supporting Resolution	WQXGA(2560x1600) / 60Hz	

### 3. Absolute Maximum Ratings

Parameter	Symbol	Minimum	Maximum	Units
Power Supply	$V_{CC}$	-0.3	+5.5	V
Operating temperature	$V_{OT}$	0	+50	°C
Storage temperature	$V_{ST}$	-20	+70	°C
Relative Humidity	$H_{RH}$	10	80	RH

**NOTICE**

Stresses greater than those listed under “Absolute Maximum Ratings” may cause permanent damage to the device. These are stress ratings only and functional operation of the device at these or any other conditions above those indicated in the operations section for extended periods of time may affect reliability.

## 4. Electrical Specification

### 4.1 Electrical Specification

#### 4.1.1 Transmitter Module

	Parameter	Symbol	Min	Typ	Max	Units	Condition
<b>P O W E R</b>	Supply Voltage (Option External Power)	$V_{CC}$	4.5	5.0	5.5	V	
	Supply Current	$I_{CC}$	-	210	260	mA	
	Power Dissipation	$P_O$	-	1.05	1.30	W	
<b>S I G N A L</b>	Diff. P-to-P Input level 1	$V_{TX-DIFF-PP1}$	0.34	0.4	0.46	V	
	Diff. P-to-P Input level 2	$V_{TX-DIFF-PP2}$	0.51	0.6	0.68	V	
	Diff. P-to-P Input level 3	$V_{TX-DIFF-PP3}$	0.69	0.8	0.92	V	
	Diff. P-to-P Input level 4	$V_{TX-DIFF-PP4}$	1.02	1.2	1.38	V	
	TX DC Common Mode	$V_{TX-DC-CM}$	0		2.0	V	
	TX AC Common Mode	$V_{TX-AC-CM}$			20	mV	

Transmitter module of Model DSFP includes 4 channel VCSEL (Vertical Surface Emitting Laser Diode) with 850, 911, 980nm invisible laser radiation.

*Do not view directly laser module of transmitter or the end of the other side of optical cable connected to transmitter with optical instrument.*

Transmitter module of DSFP is Class 1M Laser Product.

#### 4.1.2 Receiver Module

	Parameter	Symbol	Min	Typ	Max	Units	Condition
<b>P O W E R</b>	Supply Voltage (External Power)	$V_{CC}$	4.5	5.0	5.5	V	
	Supply Current	$I_{CC}$	-	230	260	mA	
	Power Dissipation	$P_O$	-	1.15	1.30	W	
<b>T M D S</b>	Diff. P-to-P Output Voltage	$V_{RX-DIFF-PP-H}$	120			mV	For HBR
	Diff. P-to-P Output Voltage	$V_{RX-DIFF-PP-R}$	40			mV	For HBR
	RX DC Common Mode	$V_{RX-DC-CM}$	0		2.0	V	

## 4.2 Connector Pin Assignment

### 4.2.1 Transmitter

Pin	Signal Assignment	Pin	Signal Assignment
1	ML_Lane0(p)	2	GND
3	ML_Lane0(n)	4	ML_Lane1(p)
5	GND	6	ML_Lane1(n)
7	ML_Lane2(p)	8	GND
9	ML_Lane2(n)	10	ML_Lane3(p)
11	GND	12	ML_Lane3(n)
13	No Connect(CONFIG1)	14	No Connect(CONFIG2)
15	AUX_CH(p)	16	GND
17	AUX_CH(n)	18	Hot Plug Detect
19	Return	20	DP_PWR

### 4.2.2 Receiver

Pin	Signal Assignment	Pin	Signal Assignment
1	ML_Lane3(n)	2	GND
3	ML_Lane3(p)	4	ML_Lane2(n)
5	GND	6	ML_Lane2(p)
7	ML_Lane1(n)	8	GND
9	ML_Lane1(p)	10	ML_Lane0(n)
11	GND	12	ML_Lane0(p)
13	No Connect(CONFIG1)	14	No Connect(CONFIG2)
15	AUX_CH(p)	16	GND
17	AUX_CH(n)	18	Hot Plug Detect
19	Return	20	No Connect(DP_PWR)

### 5 Mechanical Specification

#### 5.1 Case Dimension

##### 5.1.1 Transmitter & Receiver

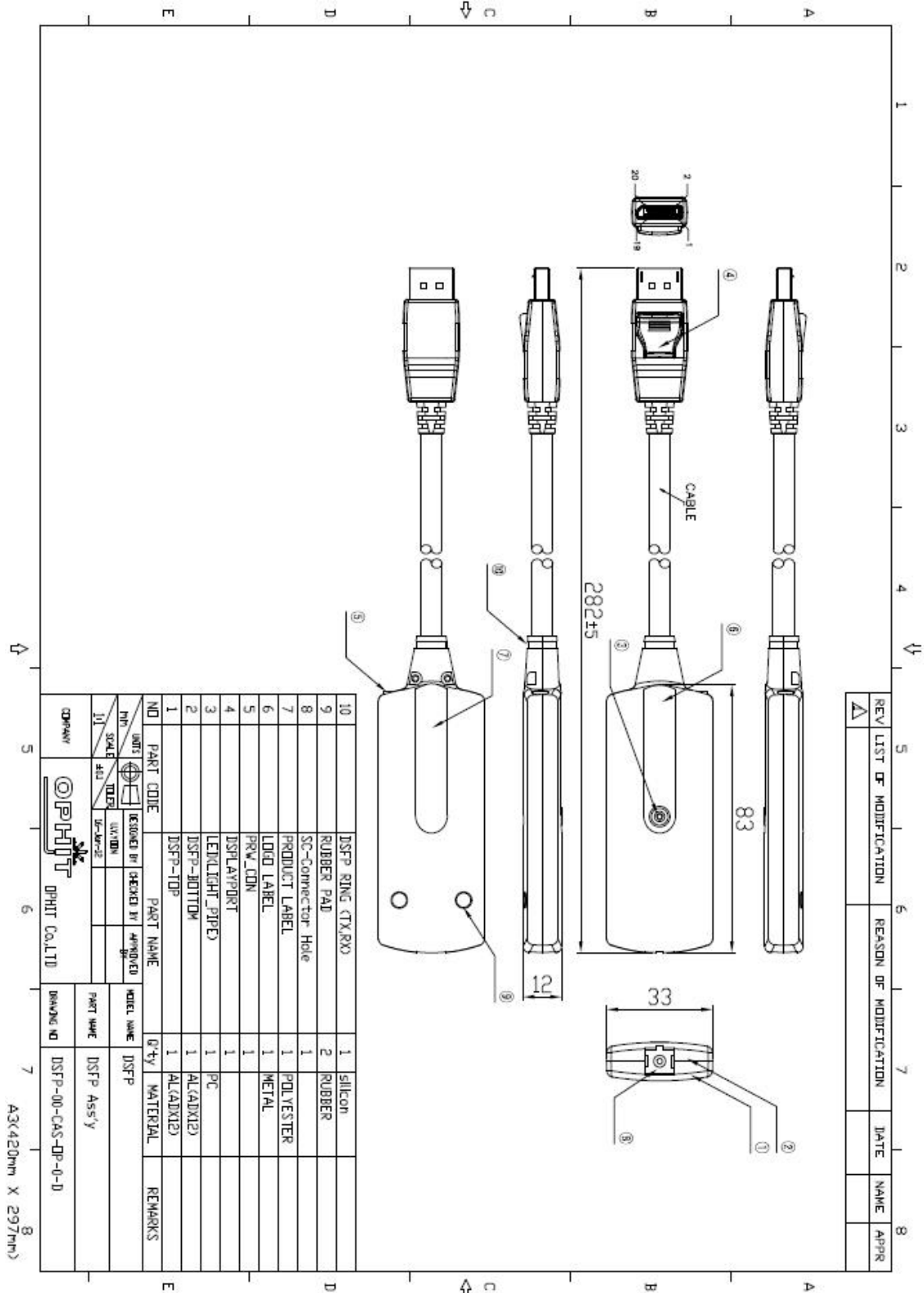



5.2 Cable

- Optical Fiber Cable (MMF 50/125)

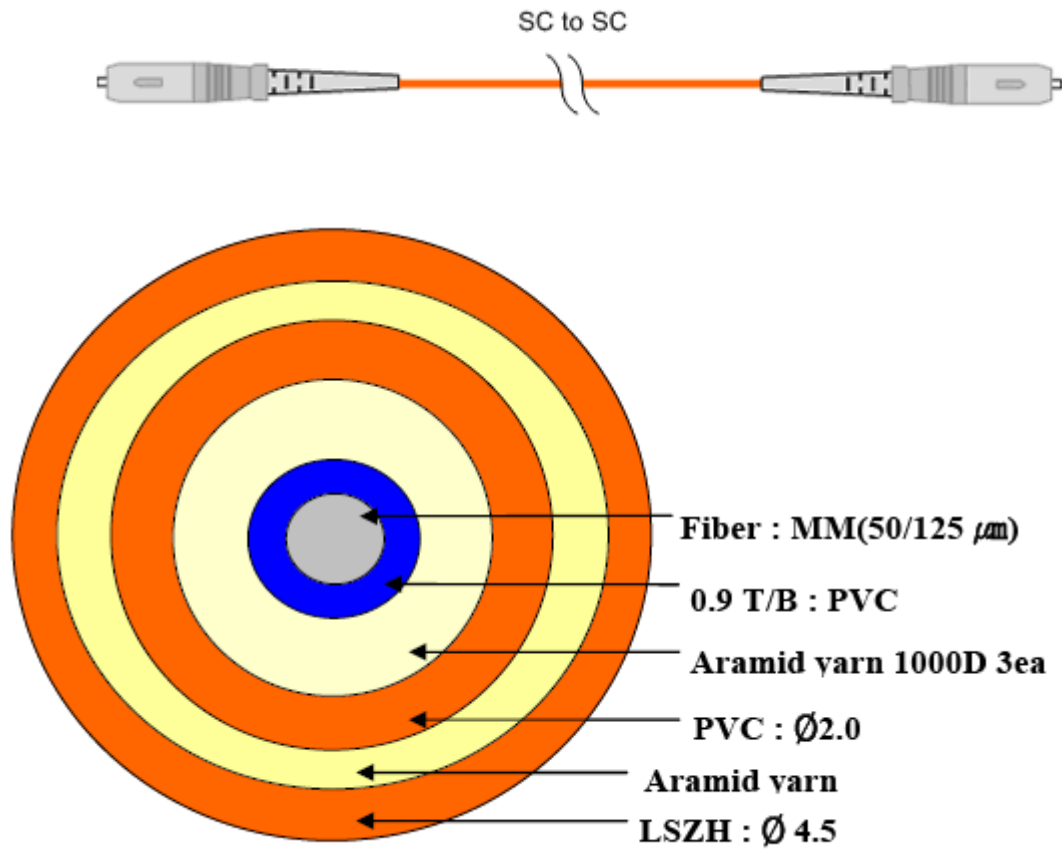

**6. RoHS****Certificate of Conformance RoHS**

Dear Customer,

On January 27, 2003, the European Parliament and the Administrative Council adopted Directive 2002/95/EC (RoHS) that concerns the "Restriction of the Use of Certain Hazardous Substances in Electrical and Electronic Equipment".

The parts currently delivered by **OPHIT CO., LTD.** are already free of lead (Pb), mercury (Hg), cadmium (Cd), hexavalent chromium (Cr 6), polybrominated biphenyl (PBB) and polybrominated diphenyl (PBDE).

This Certification of Conformance is to certify that the products listed below comply with RoHS Directive mentioned above:

- DSFP

If you have any further questions regarding the RoHS compliance of parts delivered by **OPHIT CO., LTD.**, please do not hesitate to contact us at [support@ophit.com](mailto:support@ophit.com).

Best regards,

JONG-KOOK MOON/CEO

OPHIT CO., LTD.